



---

**Model: HDSGR-24 / HDSGR-36 / HDSGR-60**

**Description: Gas range stove with oven**

**STANDARD FEATURES:**

- 15cm stainless steel legs;
- 3 rack positions and 2 wiring grids included ;
- Heavy-duty cast grates with lift-off heads;
- Thermostat control oven
- Cast iron open burners with painting
- Oven thermostat from 50-320°C
- Durable chrome coating alloy metal knobs
- Benefits:
- Crumb tray for easy cleaning
- Individual pilots and controls for each burner
- Telescoping front top ledge allows for product holding





## SPECIFICATION:

<b>HDSGR-24</b> GAS RANGE 4 OPEN BURNERS WITH OVEN	
Dimensions(LxWxH) mm	609x828x1520
Power	3/4" NPT gas connection
BTU(Open burners)	30,000x4
BTU(Oven)	30,000
Net weight	132kg
Gross weight	162kg

## View and Sizes:

### HDSGR-24

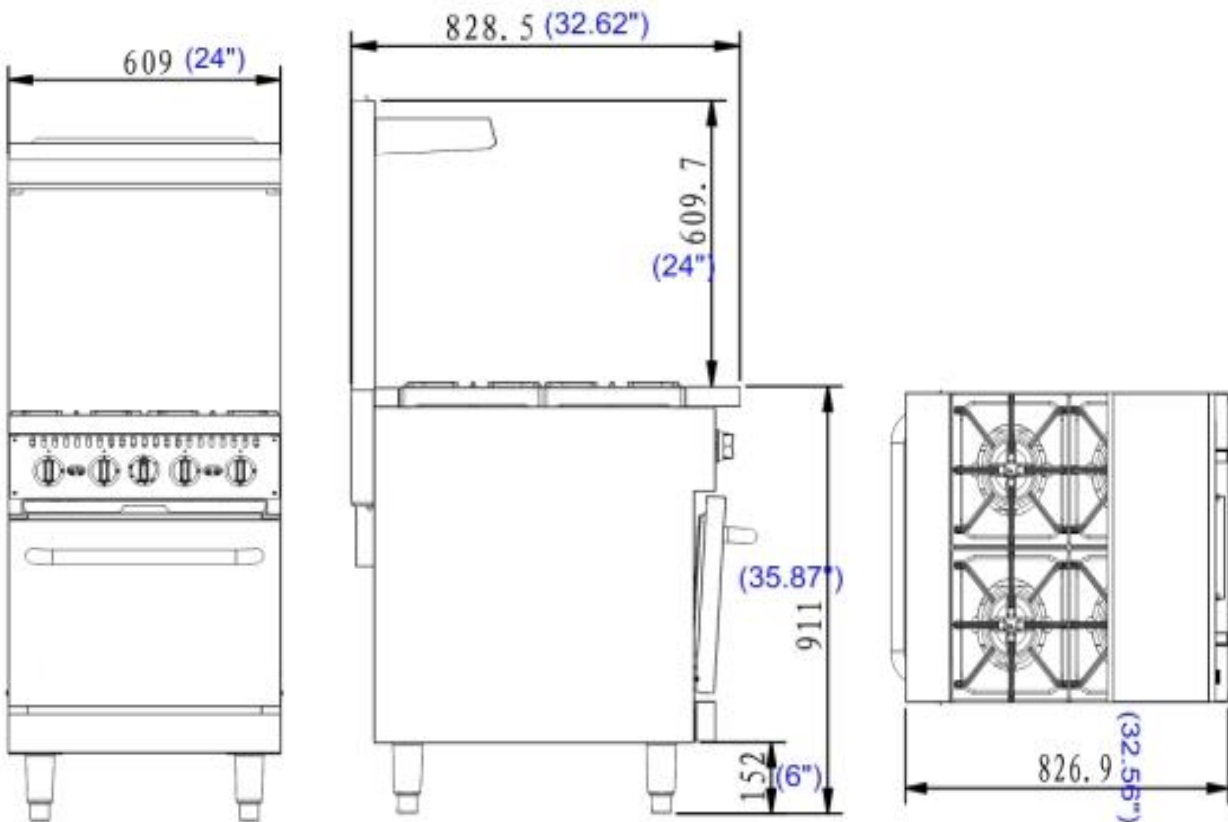

H.D Sheldon & Co. Inc  
143 West 29th Street, New York, NY 10001  
TEL: 212 924 6920 FAX: 212 627 1759 EMAIL: sales@hdsheldon.com



<b>HDSGR-36</b> GAS RANGE 6 OPEN BURNERS WITH OVEN	
Dimensions(LxWxH) mm	915x828x1520
Power	3/4" NPT gas connection
BTU(Open burners)	30,000x6
BTU(Oven)	30,000
Net weight	167kg
Gross weight	207kg

**View and Sizes:**

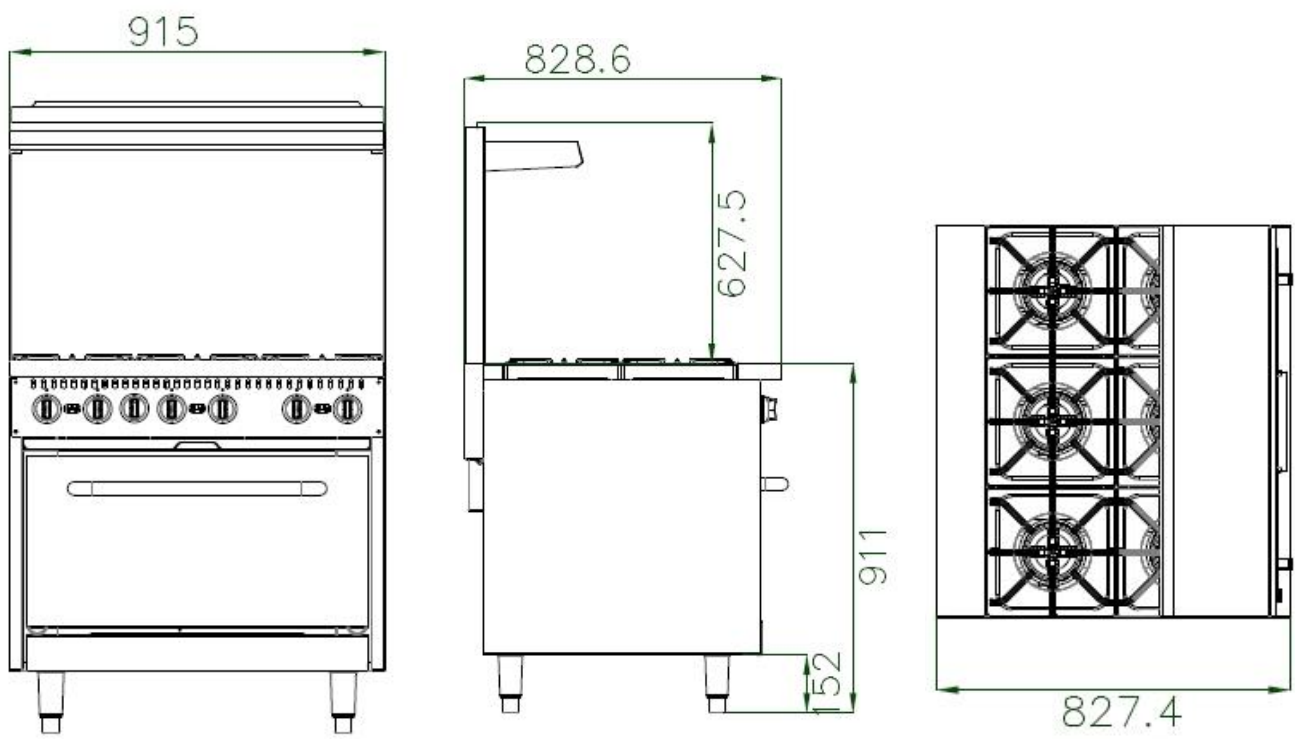



<b>HDSGR-60</b> GAS RANGE 6 OPEN BURNERS WITH DOUBLE OVENS	
Dimensions(LxWxH) mm	1524x828x1520
Power	3/4" NPT gas connection
BTU(Open burners)	30,000x10
BTU(Oven)	30000x2
Net weight	285kg
Gross weight	350kg

**View and Sizes:**

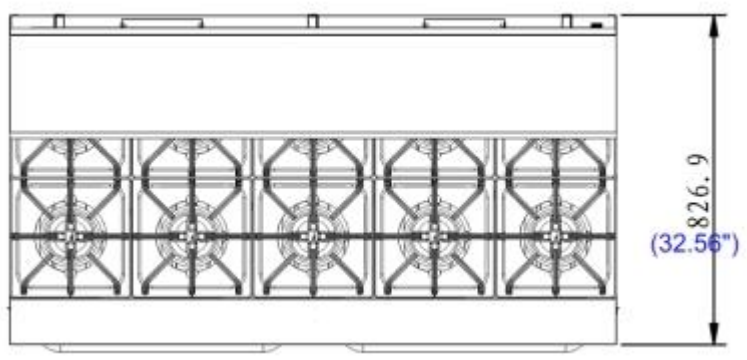
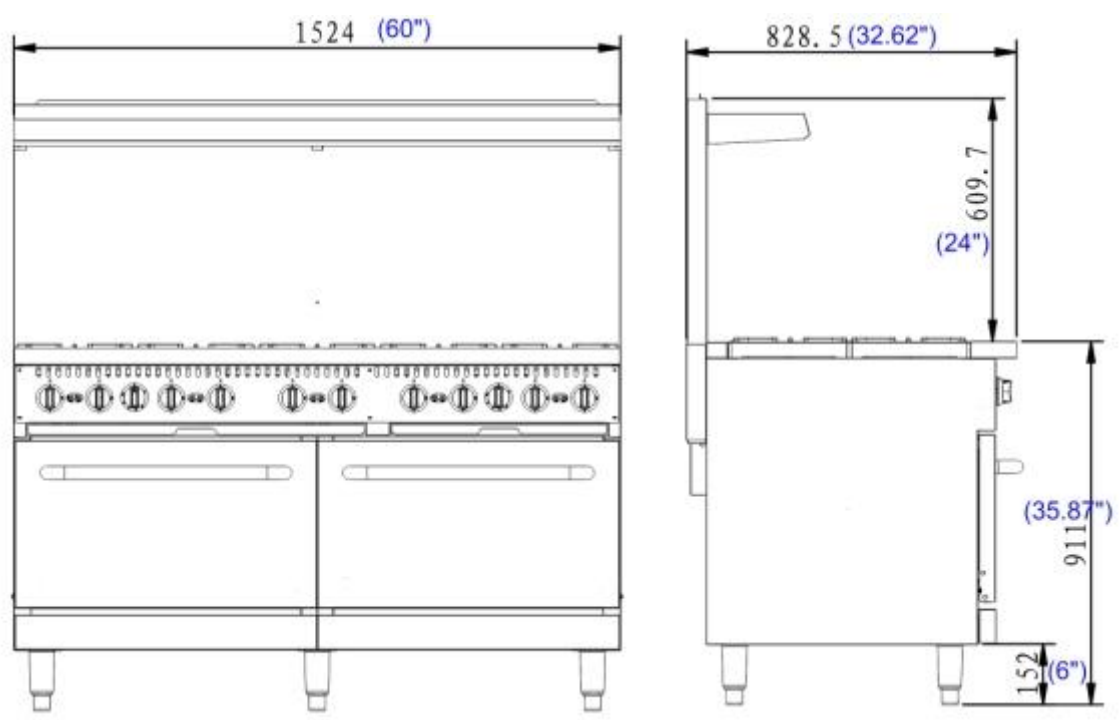

H.D Sheldon & Co. Inc  
143 West 29th Street, New York, NY 10001  
TEL: 212 924 6920 FAX: 212 627 1759 EMAIL: sales@hdsheldon.com